



DW90

Wheel Dumpers



Unbeatable off-road: the DW90 wheel dumper

Uneven ground conditions are the area of application where the wheel dumper is most at home. This is where its strengths are displayed to best advantage: hydrostatic all-wheel drive with ECO mode, exceptional off-road capability and extreme gradeability, paired with different skip versions and a wear-free spring-loaded parking brake.

- Maintenance-free hydrostatic all-wheel drive.
- Very good gradeability
- Swivel tip skip optional ex factory
- Maximum payload 9,000 kg
- For maximum comfort. Optionally with air-conditioning system



Hydrostatic all-wheel drive

- total focus on the job, no busy shifting of gears
- one central hydraulic engine drives both axles via a cardan shaft
- hydrostatic braking effect as soon as the foot is taken off the accelerator pedal
- low-wear drive for reduced service and maintenance costs
- controlled delay for regulated switching, thus no abrupt change of drive
- accelerate from 0 to maximum speed of 28km/h without traction loss

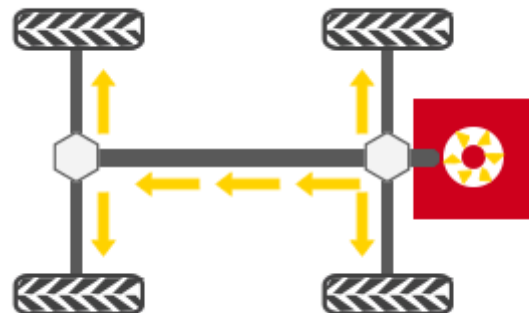

Technical specifications

	DW90 swivel tip skip	DW90 front tip skip
Operating data		
Payload kg	9,000	9,000
Net weight kg	5,611	5,183
Shipping weight ROPS kg	5,671	5,189
Shipping weight Cabin kg	5,774	5,298
Skip capacity struck l	3,300	3,750
Skip capacity heaped l	4,400	4,550



	DW90 swivel tip skip	DW90 front tip skip
Skip capacity water volume l	2,060	2,400
Engine / Motor		
Engine / Motor manufacturer	Perkins	Perkins
Engine / Motor type	854E	854E
Engine / Motor	water-cooled 4-cylinder turbo-diesel incl. intercooler	water-cooled 4-cylinder turbo-diesel incl. intercooler
Engine performance according to ISO 3046/1 kW	55	55
Displacement cm ³	3,400	3,400
Engine RPM rpm	2,200	2,200
Emissions	Level 3b/Tier 4 final	Level 3b/Tier 4 final
Traction drive	4WD, hydrostatic incl. ECO mode	4WD, hydrostatic incl. ECO mode
Travel speed km/h	25	25
Articulation angle °	29	29
Pendulum angle °	11	11
Turning radius mm	6,550	6,000
Gradeability %	50	50
Tires	500/60-22.5	500/60-22.5
L x W x H mm	5,185 x 2,465 x 2,545	4,760 x 2,465 x 3,165
Steering pump	Axial piston pump	Axial piston pump
Flow rate l/min	171	171
Operating pressure bar	450	450
Duty pump	Gear pump	Gear pump
Flow rate l/min	68	68
Operating pressure bar	235	235
Tank capacity l	83	83
Hydraulic oil tank l	60	60



Dimensions

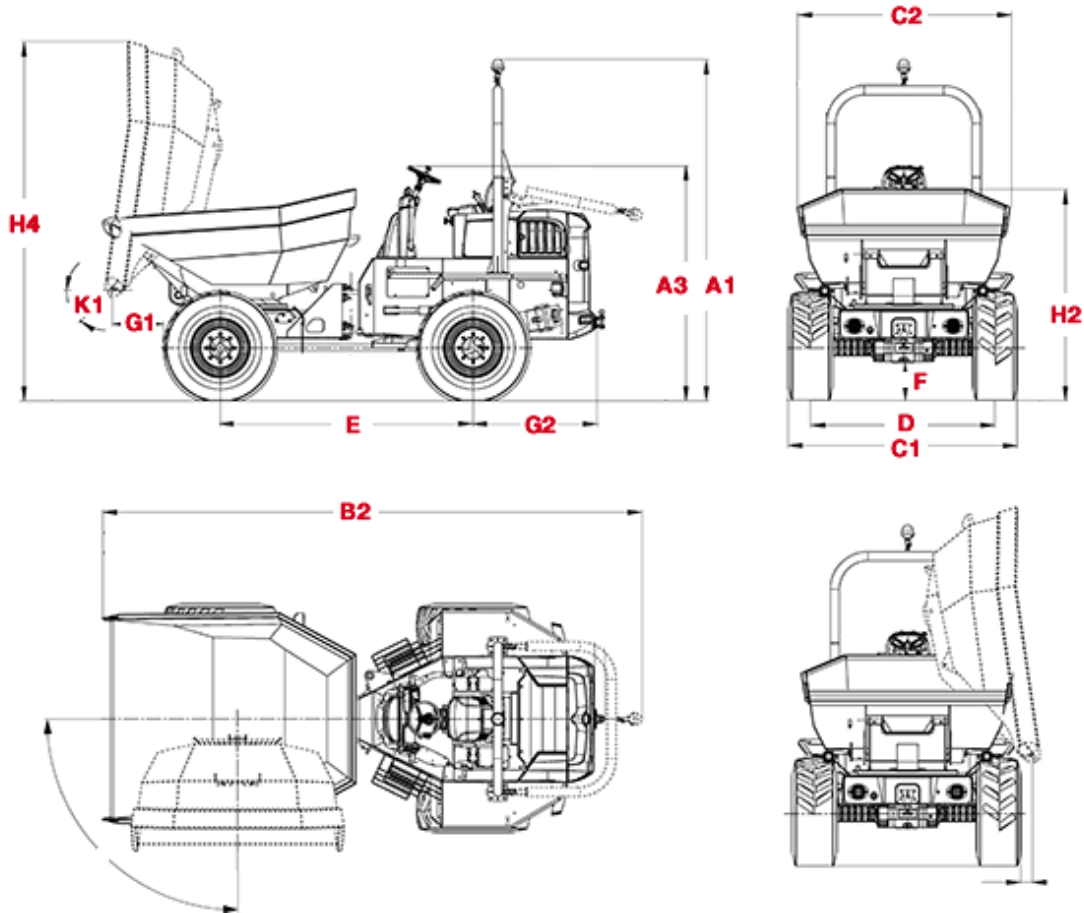

	DW90 swivel tip skip	DW90 front tip skip
B2 Length mm	5,185	4,760
C1 Overall width mm	2,465	2,465
C2 Skip width mm	2,275	2,495
H2 Skip height mm	2,305	2,250
H4 Skip height tilted mm	3,865	2,755
A1 Height ROPS mm	3,355	3,165
A3 Height ROPS tilted mm	2,545	2,355
-- Height Cabine mm	3,245	3,055
E Wheelbase mm	2,700	2,700
G2 Rear overhang mm	1,190	1,190
F Ground clearance mm	406	406



**WACKER
NEUSON**
all it takes!

Please note

that product availability can vary from country to country. It is possible that information / products may not be available in your country. More detailed information on engine power can be found in the operator's manual; the stated power may vary due to specific operating conditions.

Subject to alterations and errors excepted. Applicable also to illustrations.

Copyright © 2016 Wacker Neuson SE.