

KOBELCO

SK28SR-6/SK30SR-6/SK35SR-6

MINI EXCAVATORS

SK28SR SK30SR SK35SR



We Save You Fuel
Achieving a Low-Carbon Society

PERFORMANCE

Compact, yet, Big Performance

Wide Working Range

A larger boom and arm are provided as standard equipment to ensure a wider working range.

5,390 mm – SK35SR
5,240 mm – SK30SR
4,890 mm – SK28SR

4,990 (5,150) mm – SK35SR
4,910 (5,150) mm – SK30SR
4,620 mm – SK28SR

3,050 (2,970) mm – SK35SR
2,830 (2,780) mm – SK30SR
2,590 mm – SK28SR

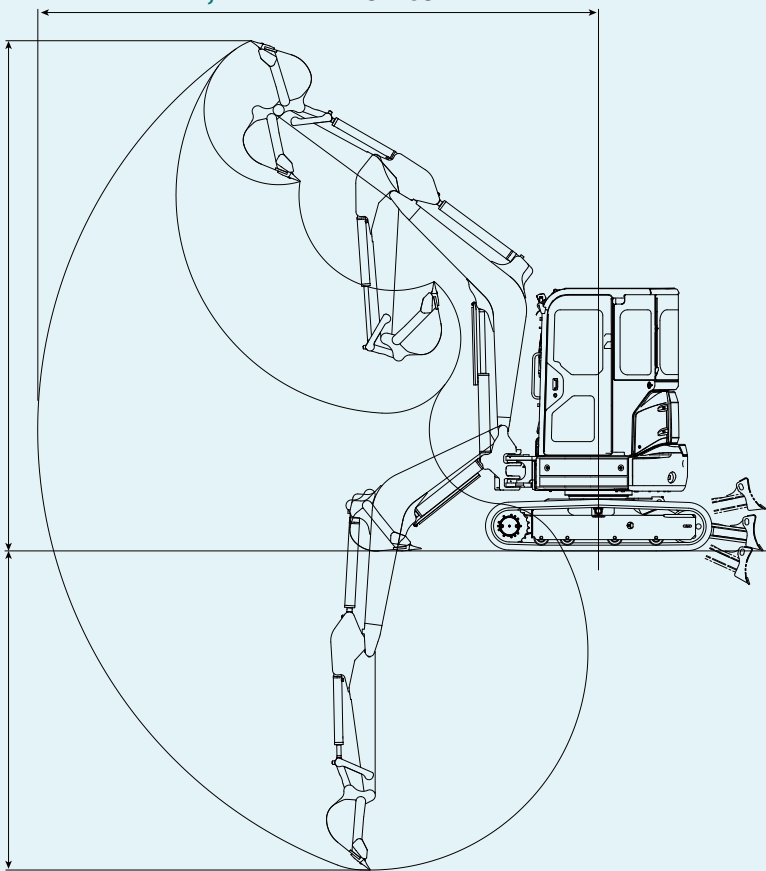

Figures in () show the value of canopy.

Short Tail Swing

The compact tail swing improves operating efficiency in limited space.

Tail overhang:
0 mm



Easy Transportability

With an overall height of 2,510 mm, the machine is designed for easy transport.



Easy Hydraulic Piping for Quick Hitch



Piping for Quick Hitch is fitted as standard.

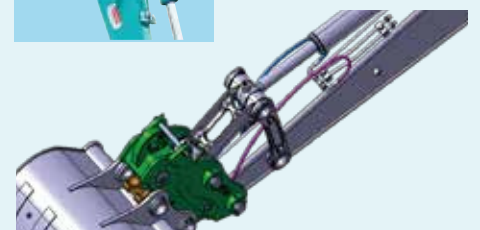

SPECIFICATIONS

MODEL		SK28SR	SK30SR	SK35SR	
Type		SK28SR-6	SK30SR-6	SK35SR-6	
Machine Mass	Cab	kg	2,950	3,380	3,770
	Canopy	kg	2,790	3,220	3,630
Bucket Capacity		m ³	0.08	0.09	0.11
Bucket Width (with side cutter)		mm	500	500	600
Arm Length		m	1.18	1.32	1.37
Bucket Digging Force		kN	24.7	27.7	27.8
Arm Crowding Force		kN	16.6	19.1	22.4
ENGINE					
Model		YANMAR 3TNV82A-B			
Type		Water cooled, 4-cycle, 3-cylinder, direct injection, diesel engine			
Power Output	(ISO 9249)	kW/min ⁻¹	17.1/2,400		
	(ISO 14396)	kW/min ⁻¹	18.1/2,400		
Max. Torque	(ISO 9249)	N-m/min ⁻¹	77.7/1,440		
	(ISO 14396)	N-m/min ⁻¹	79.4/1,440		
Displacement		L	1.331		
Fuel Tank		L	42		
HYDRAULIC SYSTEM					
Pump		Two variable displacement pumps + One gear pump			
Max. Discharge Flow	L/min	2 x 28.8, 1 x 16.1	2 x 38.4, 1 x 19.2		
Relief Valve Setting	MPa	23.0			
Hydraulic Oil Tank (system)	L	20.4 (41.1)	20.4 (44.8)	20.4 (44.8)	
TRAVEL SYSTEM					
Travel Motors		2 x axial-piston, two-step motors			
Parking Brake		Oil disc brake per motor			
Travel Speed (high/low)	km/h	3.8/2.1	4.4/2.5	4.4/2.5	
Gradeability	% (degree)	58 (30)			
Drawbar Pulling Force	Cab	kN	34.8	38.3	38.1
	Canopy	kN	34.9	38.4	38.2
CRAWLER					
Shoe		mm	Rubber		
Shoe Width		mm	300		
Ground Pressure	Cab	kPa	26.3	30.1	33.5
	Canopy	kPa	24.9	28.7	32.2
DOZER BLADE					
Width x Height	mm	1,550 x 345	1,550 x 345	1,700 x 345	
SWING SYSTEM					
Swing Motor		Axial piston motor			
Parking Brake		Oil disc brake, hydraulic operated automatically			
Swing Speed	min ⁻¹	8.4			
SIDE DIGGING MECHANISM					
Type		Boom swing			

WORKING RANGES

Unit: mm

MODEL	SK28SR	SK30SR		SK35SR	
		Cab	Canopy	Cab	Canopy
Arm length	1.18 m	1.32 m		1.37 m	
a- Max. digging reach	4,890	5,240		5,390	
b- Max. digging reach at ground level	4,730	5,080		5,240	
c- Max. digging depth	2,590	2,830	2,780	3,050	2,970
d- Max. digging height	4,620	4,910	5,150	4,990	5,150
e- Max. dumping clearance	3,210	3,510	3,730	3,600	3,750
f- Min. dumping clearance	1,330	1,320	1,470	1,330	1,420
g- Max. vertical wall digging depth	2,410	2,510		2,620	
h- Min. swing radius at boom swing	2,330	2,430	2,310	2,380	2,320
	2,040	2,030	2,010	1,980	2,010
i- Horizontal digging stroke at ground level	1,810	2,140		2,320	
j- Dozer blade (height/depth)	450/370	470/400		470/400	

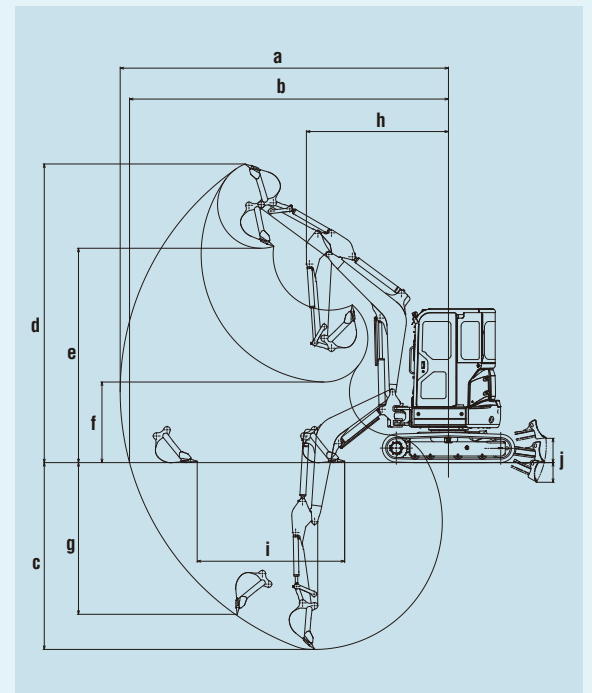

GENERAL DIMENSIONS

Unit: mm

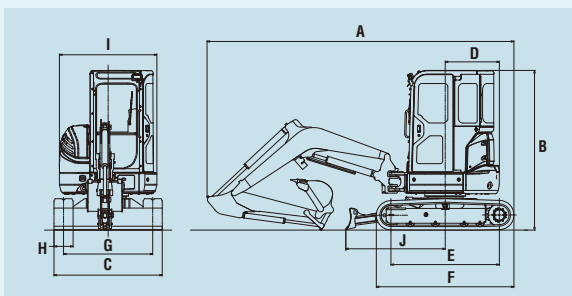

MODEL	SK28SR	SK30SR	SK35SR
A Overall length	4,550	4,760	4,870
B Overall height	2,510	2,510	2,510
C Overall width	1,550	1,550	1,700
D Tail swing radius	775	775	850
E Tumbler distance	1,700	1,700	1,700
F Overall length of crawler	2,160	2,160	2,160
G Track gauge	1,250	1,250	1,400
H Shoe width	300	300	300
I Overall width of upperstructure	1,530	1,530	1,530
J Distance from dozer top to center of upperstructure	1,500	1,560	1,560

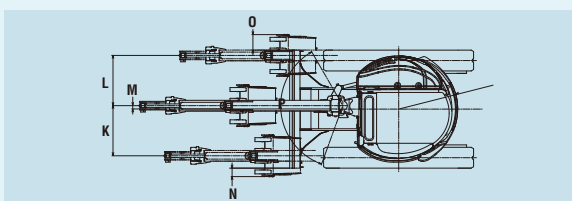

MODEL	SK28SR	SK30SR	SK35SR
K Boom offset volume (right)	680	720	720
L Boom offset volume (left)	675	725	725
M Offset volume of boom center	50	50	50
N Digging distance outside crawler shoe (right)	100	150	120
O Digging distance outside crawler shoe (left)	200	250	225
P Boom swing angle (left/right)	60°/55°	70°/60°	70°/60°

OPTIONAL EQUIPMENT

• N&B (HCP*) piping	• Bolt-on Pad shoes (for steel shoes)	• BHL lever
• N&B (foot) piping + Rotating N&B (HCP*)	• Add-on counterweight (250 kg) + 90 mm tail swing radius	• Multi-control valve
• N&B (HCP*) piping + Rotating N&B (HCP*)	• Boom & arm holding valve	• Arm & bucket cylinder cover
• ROPS cab with air conditioner	• Wide range of buckets	• Front guard
• Radio (only for cab)	• Rear view mirror	• 12 V power source
• Steel shoe	• Rear under mirror	• 4-way blade (only for SK35SR)

*Hand Control Proportional

LIFTING CAPACITIES

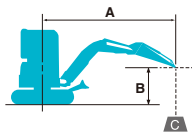

Rating over front

Rating over side or 360 degrees

A: Reach from swing centerline to arm top
 B: Arm top height above/below ground
 C: Lifting capacities in kilograms
 Bucket: Without bucket Dozer blade: up
 Relief valve setting: 23.0 MPa

SK28SR Cab		Arm: 1.18 m, Bucket: without Shoe: 300 mm										
B \ A		1.0 m		2.0 m		3.0 m		4.0 m		At Max. Reach		Radius
3.0 m	kg					*630	490			510	370	3.51 m
2.0 m	kg			*1,150	890	640	470	400	290	400	290	4.00 m
1.0 m	kg					600	430	390	280	370	260	4.12 m
G. L.	kg			1,110	730	570	400			390	280	3.92 m
-1.0 m	kg	*2,090	*2,090	1,130	750	580	410			500	350	3.32 m

SK28SR Canopy		Arm: 1.18 m, Bucket: without Shoe: 300 mm										
B \ A		1.0 m		2.0 m		3.0 m		4.0 m		At Max. Reach		Radius
3.0 m	kg					*630	470			480	350	3.51 m
2.0 m	kg			*1,150	850	610	440	370	270	370	270	4.00 m
1.0 m	kg					560	400	360	260	340	250	4.12 m
G. L.	kg			1,040	690	540	380			360	260	3.92 m
-1.0 m	kg	*2,090	*2,090	1,050	700	540	380			470	330	3.32 m

SK30SR Cab		Arm: 1.32 m, Bucket: without Shoe: 300 mm										
B \ A		1.0 m		2.0 m		3.0 m		4.0 m		At Max. Reach		Radius
4.0 m	kg					780	620			740	590	3.08 m
3.0 m	kg									480	380	3.97 m
2.0 m	kg					740	580	460	370	400	310	4.38 m
1.0 m	kg					680	530	440	350	370	290	4.48 m
G. L.	kg			1,250	910	650	500	430	330	390	300	4.29 m
-1.0 m	kg	*2,050	*2,050	1,270	930	650	500			470	370	3.77 m
-2.0 m	kg			*970	*970					*640	*640	2.60 m

SK30SR Canopy		Arm: 1.32 m, Bucket: without Shoe: 300 mm										
B \ A		1.0 m		2.0 m		3.0 m		4.0 m		At Max. Reach		Radius
4.0 m	kg					740	590			700	560	3.08 m
3.0 m	kg									450	360	3.97 m
2.0 m	kg					700	550	440	350	370	300	4.38 m
1.0 m	kg					640	500	420	330	350	270	4.48 m
G. L.	kg			1,180	860	610	470	400	320	370	290	4.29 m
-1.0 m	kg	*2,050	*2,050	1,200	880	610	470			450	350	3.77 m
-2.0 m	kg			*970	930					*640	620	2.60 m

SK35SR Cab		Arm: 1.37 m, Bucket: without Shoe: 300 mm										
B \ A		1.0 m		2.0 m		3.0 m		4.0 m		At Max. Reach		Radius
4.0 m	kg									800	750	3.32 m
3.0 m	kg									550	520	4.15 m
2.0 m	kg					900	840	570	540	470	440	4.54 m
1.0 m	kg					830	780	550	520	440	420	4.63 m
G. L.	kg			1,530	1,390	800	740	530	500	460	430	4.45 m
-1.0 m	kg	*2,290	*2,290	1,550	1,400	800	740			550	510	3.95 m
-2.0 m	kg			*1,550	1,460					880	820	2.90 m

SK35SR Canopy		Arm: 1.37 m, Bucket: without Shoe: 300 mm										
B \ A		1.0 m		2.0 m		3.0 m		4.0 m		At Max. Reach		Radius
4.0 m	kg									770	720	3.32 m
3.0 m	kg									530	500	4.15 m
2.0 m	kg					860	810	560	530	450	420	4.54 m
1.0 m	kg					800	740	520	490	420	400	4.63 m
G. L.	kg			1,460	1,330	760	710	510	480	440	410	4.45 m
-1.0 m	kg	*2,290	*2,290	1,480	1,350	760	710			520	490	3.95 m
-2.0 m	kg			1,540	1,400					840	790	2.90 m

Notes:

- Do not attempt to lift or hold any load that is greater than these lifting capacities at their specified lift point radius and heights. Weight of all accessories must be deducted from the above lifting capacities.
- Lifting capacities are based on machine standing on level, firm, and uniform ground. User must make allowance for job conditions such as soft or uneven ground, out of level conditions, side loads, sudden stopping of loads, hazardous conditions, experience of personnel, etc.
- Arm top defined as lift point.

- The above lifting capacities are in compliance with ISO 10567. They do not exceed 87% of hydraulic lifting capacity or 75% of tipping load. Lifting capacities marked with an asterisk (*) are limited by hydraulic capacity rather than tipping load.
- Operator should be fully acquainted with the Operator's and Maintenance Instructions before operating this machine. Rules for safe operation of equipment should be adhered to at all times.
- Lifting capacities apply to only machine as originally manufactured and normally equipped by KOBELCO CONSTRUCTION MACHINERY CO., LTD.

Note: This catalog may contain attachments and optional equipment that are not available in your area. And it may contain photographs of machines with specifications that differ from those of machines sold in your areas. Please consult your nearest KOBELCO distributor for those items you require. Due to our policy of continuous product improvements all designs and specifications are subject to change without advance notice.

Copyright by **KOBELCO CONSTRUCTION MACHINERY CO., LTD.** No part of this catalog may be reproduced in any manner without notice.

KOBELCO CONSTRUCTION MACHINERY CO., LTD.

5-5-15 kitashinagawa, Shinagawa-ku, Tokyo 141-8626 JAPAN
 Tel: +81 (0) 3-5789-2146 Fax: +81 (0) 3-5789-2135
www.kobelco-kenki.co.jp/english_index.html

Inquiries To: